

NUMMECH PRODUCTS

TIPPMANN CROSSOVER DROP FORWARD

This drop forward is intended to mimic the stock bottomline system used by the Crossover marker. Please read these instructions before your installation. An installation video can be found on our website www.nummech.com.

Installation:

Tip: when working on your paintball marker, please note that most screws should be tightened only hand-tight. This will prevent stripped screws in the future.

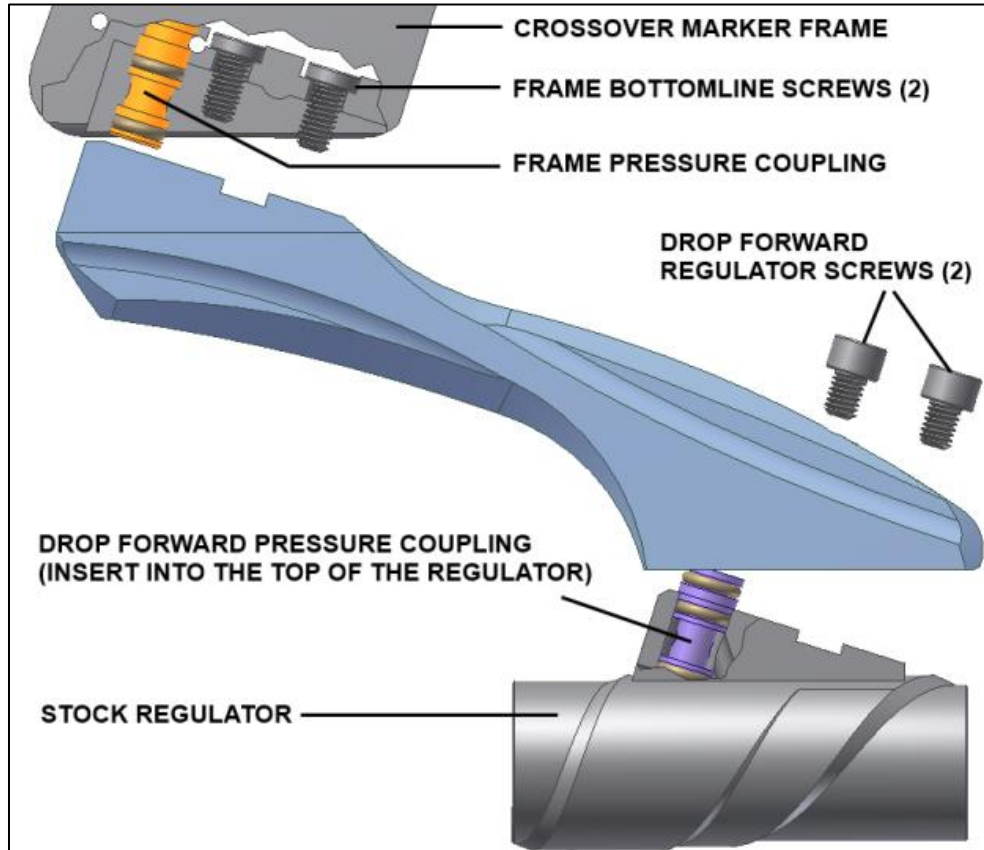

1. Start by removing your marker's grip panels and battery.
2. Remove the stock bottomline regulator by unscrewing the two button head cap screws located in the battery compartment (use a 1/8" allen key). This is also a good time to clean and lubricate the brass pressure coupling's o-rings while the ASA is removed.
3. Position the drop forward onto the frame's pressure connection, then gently slide them together. Use the two factory screws to secure the drop forward onto the Crossover frame.
4. The drop forward ships with its pressure coupling pre-installed in its bottom cavity (unless it fell out during transit). Remove the coupling and gently insert it into the top of your stock regulator.
5. Install your stock regulator onto the bottom of the drop forward by gently aligning the top of the pressure coupling with the hole in the bottom of the drop. Use the two new screws provided with the drop forward to secure the reg (the screws use a 5/32" allen key).
6. Once the new drop forward is correctly installed onto your marker, it's a good idea to test out the pressure connection to make sure the marker is ready for use. To do this, install your tank onto the ASA and listen for any leaks. You may need to re-lubricate the coupling o-rings in the event of a leak.